

Aerial lift / platform wagon



Design and production of complete, fitted wagons or modules on request:

- ✓ Aerial personnel lift
 - articulated telescopic boom structure
 - swivelling lift platform structure
- ✓ Offsetting / track axle device
- ✓ Telescopic crane with adaptable basket
- ✓ Energy and hydraulic packs

PVI provides, on request and according to the level of technical integration of its Customers:

- ✓ Needs analysis and feasibility studies
- ✓ Design studies for installation on an existing wagon or new base
- ✓ Regulations and norms approvals
- ✓ Technical support missions (assembly of modules by the Customer)
- ✓ Technical start-up assistance

To **preserve the environment** on your sites (noise and polluting emissions) and to **protect staff** working in confined areas, **PVI offers electric drivelines** on its aerial lift / platform wagons.



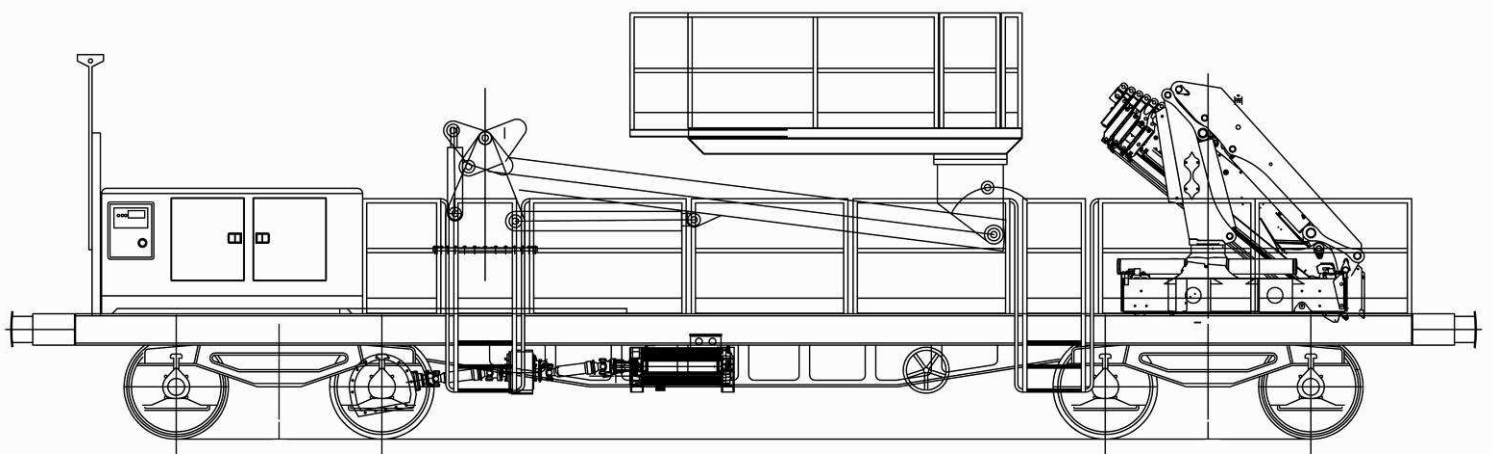

Aerial lift platform

Aerial personnel lift with an articulated telescopic structure
 Oriented jib boom 180° to avoid obstacles and structures
 2x90° swivelling basket
 Track axle offsetting device to exit from catenary area
 Basket capacity 2 persons + tools
 Working height from 16 to 21 m
 Mobile balance weight built into the chassis for a perfect stability without alteration of the axle loading



Platform module

Dual orientation personnel lifting platform:

- Turret base
- Platform base

Platform capacity: 4 to 7 persons + tools
 Working height 14 m
 Mobile balance weight built into the chassis for a perfect stability without alteration of the axle loading

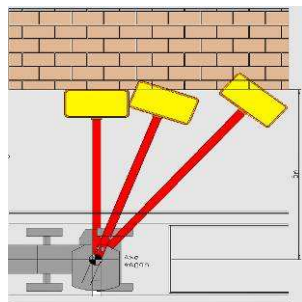

Safety system management

Work area management for safe working on partially closed lines
 Implementation of customized personal electronic safety systems (virtual wall) enabling risk-free deployment of structures, both statically and dynamically
 Movement control of the wagon in the basket; smooth and accurate movements thanks to the electric driveline

PVI Ferroviaire

Rue Maison Rouge - BP 40091 GRETZ ARMAINVILLIERS - 77223 TOURNAN CEDEX - FRANCE
 Tel. (+33)1 64 42 14 08 - Fax (+33)1 64 07 19 04 - Email : ferroviaire@pvi.biz